

PREPAC "PREFERENCE" RANGE

Semi-instantaneous Production of Domestic Hot Water

500 to 3 000 liters - 41 to 332 kW

Monobloc • Efficient • Economical

PRESENTATION

The "PREPAC" is a compact monobloc system for the production of domestic hot water, consisting of a buffer tank and an efficient heat exchanger module (plate exchanger, circulator, zone valves, thermostat, piping in stainless steel).

The new inner lining "RC851", developed through a lengthy process of research (R&D service, research laboratory), is now supplied with all the tanks in the "Preference" range. This new interior protection, perfected through a series of rigorous tests, is the result of technical collaboration with the best European specialists in the field. It benefits from an HCA Certificate (Health Conformity Attestation).

HOW IT WORKS

The domestic water contained in the buffer tank is drawn on the lower part of the tank and continuously crosses the plate exchanger due to the secondary circulator. The heated water is stored on the upper part of the tank to provide an important reserve. The thermostat allows the primary pump (if installed when provided) to stop working when the desired temperature is reached.



ADVANTAGES

- **Tank designed** according to **D.G.S.** recommendations relative to the **prevention** of **Legionnaire's disease**.
- Inner lining with **HCA** (Health Conformity Attestation), benefiting from the latest technical advances.
- **Hot water reserve** allowing **important** instantaneous **consumption**.
- **Efficient** (high plate heat exchange coefficient).
- **Compact** (monobloc assembly).
- **Simple** and **rapid installation** (module delivered pre-assembled).
- **Easy maintenance** (completely demountable module).
- Jackets fire rated by the **CSTB** (Centre for Science and Technology in Buildings) or the **NTL** (National Testing Laboratory).
- Flexible jacket thickness 60 mm ($\lambda = 0,032 \text{ W/m/K}$).
- **Insulation for inferior dished end** (flexible jacket version) and **manhole** according to model.
- Insulating jackets, conforming to **NF C 73221.1** standard.
- Respects thermal regulation **RT 2005**.
- Site delivery with **insulation** and **equipment mounted**.

DESCRIPTION

TANK

- 500 to 3 000 liters capacities.
- Vertical in 1st quality steel.
- 3 support feet.
- Working pressure = max. 7 bar.
- Test pressure = 10 bar.
- Tapping according to plan below.

INNER LINING (HCA.)

- Finishing coating "RC851".
- T° maximum = 85°C.
- Magnesium protection anode.

EXTERIOR PROTECTION

- Anti-rust paint.

REMOVABLE THERMAL INSULATION (Including manhole)

- **Fire rating M1:**
 - Mineral wool thickness 60 mm. (including inferior dished end).
 - Flexible PVC jacket (including inferior dished end).
- **Fire rating M0:**
 - Rock wool thickness 50 mm (40 kg/m³).
 - Isoxal metal sheet jacket.

EQUIPMENT

- Demountable plate exchanger made of stainless steel AISI 316 L.
- Connecting piping in stainless steel AISI 316.
- Stainless steel secondary circulator.
- Double safety thermostat 0/90°C.
- Zone valves exchanger / circulator.

OPTIONS

- Accessory kit (thermometer, DN 25 valve, DN 50 valve for drainage, air vent).
- Inspection manhole ø 400 mm.
- Other capacities, powers and temperatures.
- Non standard dimensions and tapping*.
- Higher working pressure (e.g. 10, 12 bar)*.

WARRANTIES (according to our general sales conditions)

- Tank = **5 years**.
- Electrical equipment & and accessories = **1 year**.

*LACAZE ENERGIES can manufacture tanks to custom requirements in respect of working pressure and capacities.

AVAILABLE MODELS

Plate exchangers			
Exchanger power (kW)	Primary 90°C		Sec. 10/55°C
	Flow (m ³ /h)	Δ p (mCE)	Flow (m ³ /h)
41	1.26	2.90	0.79
49	1.26	1.69	0.94
66	2.02	2.70	1.26
77	2.12	2.12	1.48
87	2.41	2.70	1.66
94	2.59	3.10	1.80
100	2.52	2.20	1.91
106	2.48	1.67	2.02
136	3.71	2.88	2.59
143	3.89	3.16	2.74
154	3.89	2.61	2.95
222	5.83	3.09	4.25
252	6.44	2.96	4.82
266	6.77	3.26	5.08
301	7.60	3.06	5.76
332	8.24	3.06	6.34

Tanks				
Capacity (litres)	D	D + 350	H	I to IV
500	650	1.000	1.760	50/60
750	800	1.150	1.820	50/60
1000 H	800	1.150	2.370	50/60
1000 B ⁽²⁾	950	1.300	1.890	50/60
1500 H ⁽²⁾	950	1.300	2.440	50/60
1500 B ⁽²⁾	1.100	1.450	1.960	50/60
2000 H ⁽²⁾	1.100	1.450	2.510	50/60
2000 B ⁽²⁾	1.300	1.650	2.060	50/60
2500	1.300	1.650	2.310	50/60
3000	1.300	1.650	2.610	50/60

⁽²⁾Note :
H = High version - B = Low version.

Key:

- EF Cold water inlet with baffle: threaded tapping 50/60.
- EC Hot water outlet: threaded tapping 50/60.
- DA Loop exit / entry, threaded tapping 50/60.
- VM Drainage: threaded tapping 50/60.
- TG Couplings 15/21 for thermometer and thermostat.
- PR M77 boss for mounting of immersion heater (welded on manhole if present, if not on the tank).
- PI Support legs.
- AN1 Coupling 40/49 for anode.
- TO Manhole ø int. 400 mm (nozzle ø int. 250 mm on 300 liters tank), optional.
- EP Primary inlet exchanger 26/34 (threaded).
- SP Primary outlet exchanger 26/34 (threaded).
- 1 Tank.
- 2 Secondary circulator.
- 3 Plate exchanger (connections DN 25).
- 4 Isolation valve.

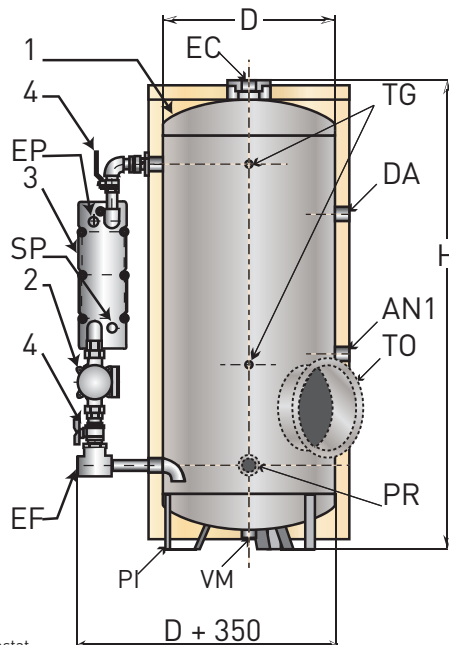

PREPAC "INOX" STAINLESS STEEL RANGE

Semi-instantaneous Production of Domestic Hot Water

500 to 3 000 liters - 41 to 332 kW

Monobloc • Efficient • Economical

PRESENTATION

The "PREPAC INOX" is a compact monobloc system for the production of domestic hot water, consisting of a buffer tank and an efficient heat exchanger module (plate exchanger, circulator, zone valves, thermostat, piping in stainless steel).

The use of a stainless steel AISI 316 L tank offers all the security of domestic quality and durability.

HOW IT WORKS

The domestic water contained in the buffer tank is drawn on the lower part of the tank and continuously crosses the plate exchanger due to the secondary circulator.

The heated water is stored in the upper part of the tank to provide an important reserve.

The thermostat allows the primary pump (not supplied) to stop working when the desired temperature is reached.



ADVANTAGES

- Tank designed according to **DGS** recommendations relative to the **prevention of Legionnaire's disease**.
- Great longevity (**stainless steel AISI 316 L**, with welding outside and inside).
- Hot water **reserve** allowing **important** instantaneous consumption to be confronted.
- **Efficient** (high plate heat exchange coefficient).
- **Compact** (monobloc assembly).
- **Simple** and **rapid installation** (module delivered pre-assembled).
- **Easy maintenance** (completely demountable module).
- Jackets **fire** rated by the **CSTB** (Centre for Science and Technology in Buildings) or the **NTL** (National Testing Laboratory).
- **Flexible** jacket thickness **60 mm** ($\lambda = 0,032 \text{ W/m/K}$).
- **Inferior end** (flexible jacket version) and **manhole** insulated according to model.
- Thermal insulation conforms to **NF C 73221.1** standard.
- Respects thermal regulation **RT 2005**.
- Delivered to site with **insulation** and **thermal equipment pre-mounted**.

DESCRIPTION

TANK

- Capacities from 500 to 3000 liters, with inspection manhole⁽¹⁾ ø 400 mm.
- Vertical in stainless steel AISI 316 L.
- Interior **and** exterior welding.
- Three support feet.
- Working pressure = max. 7 bar.
- Test pressure = 10 bar.
- Tapping (according to plan below).

EXTERIOR/INTERIOR TREATMENT

- Passivation.

REMOVABLE THERMAL INSULATION (including inspection manhole)

Fire rating M1

- Mineral wool th. 60 mm (including inferior dished end).
 - PVC flexible jacket
- or:
- Rock wool th. 50 mm (40 kg/m³).
 - Isoxal metal sheet jacket.

EQUIPMENT

- Demountable plate exchanger made of stainless steel AISI 316 L.
- Connection pipes in stainless steel AISI 316.
- Stainless steel secondary circulator.
- Double safety thermostat 0/90°C.
- Exchanger/circulator zone valves.

OPTIONS

- Accessory kit (thermometer, DN 25 valve, DN 50 valve for drainage, air vent).
- Other capacities, powers and temperatures.
- Non standard dimensions and tapping*.
- Higher working pressure (e.g. 10, 12 bar)*.

WARRANTIES (according to our general sales conditions)

- Tank = **7 years**.
- Electrical equipment and accessories = **1 year**.

⁽¹⁾Note: in conformity with Health and Safety recommendations.

*LACAZE ENERGIES can manufacture tanks to custom requirements in respect of working pressure and capacities.

AVAILABLE MODELS

Plate exchangers			
Exchanger power (kW)	Primary 90°C		Sec. 10/55°C
	Flow (m ³ /h)	Δ p (mCE)	Flow (m ³ /h)
41	1.26	2.90	0.79
49	1.26	1.69	0.94
66	2.02	2.70	1.26
77	2.12	2.12	1.48
87	2.41	2.70	1.66
94	2.59	3.10	1.80
100	2.52	2.20	1.91
106	2.48	1.67	2.02
136	3.71	2.88	2.59
143	3.89	3.16	2.74
154	3.89	2.61	2.95
222	5.83	3.09	4.25
252	6.44	2.96	4.82
266	6.77	3.26	5.08
301	7.60	3.06	5.76
332	8.24	3.06	6.34

Tanks				
Capacity (liters)	D	D + 350	H	I to IV
500	650	1.000	1.760	50/60
750	800	1.150	1.820	50/60
1000 H	800	1.150	2.370	50/60
1000 B ⁽²⁾	950	1.300	1.890	50/60
1500 H ⁽²⁾	950	1.300	2.440	50/60
1500 B ⁽²⁾	1.100	1.450	1.960	50/60
2000 H ⁽²⁾	1.100	1.450	2.510	50/60
2000 B ⁽²⁾	1.300	1.650	2.060	50/60
2500	1.300	1.650	2.310	50/60
3000	1.300	1.650	2.610	50/60

⁽²⁾Note :
H = High version - B = Low version.

- Key:**
- 1 Tank.
 - 2 Secondary circulator.
 - 3 Plate exchanger (connections DN 25).
 - 4 Coupling 15/21 for thermostat.
 - 5 Zone valves.
 - 6 Coupling 15/21 for thermometer (optional).
 - 8 M77 threaded mounting plate for heating element (plug supplied).
 - I Hot water outlet: 50/60 coupling.
 - II Loop departure/return: 50/60 couplings.
 - III Cold water inlet (with deflector): 50/60 coupling.
 - IV Threaded drain DN 50.
 - V Exchanger primary inlet 26/34.
 - VI Exchanger primary outlet 26/34.

